

	page
<b>FRONT SUSPENSION</b>	
- Removing-refitting	1
- Dismantling-Reassembly	6
- Wheel hub	9
- Coil spring and shock absorber assembly	13
- Stabilizer bar	14
<b>REAR SUSPENSION</b>	
- Removing-refitting	15
- Dismantling-Reassembly	20
- Wheel hub	21
- Coil spring and shock absorber assembly	25
<b>WHEEL GEOMETRY</b>	
- Front wheel geometry	26
- Rear wheel geometry	27
<b>SPECIAL TOOLS</b>	28

### REMOVING-REFITTING

#### Front suspension assembly

In order to remove and refit the front suspension, position the vehicle on a lift and after having removed the front wheels, proceed as illustrated below.

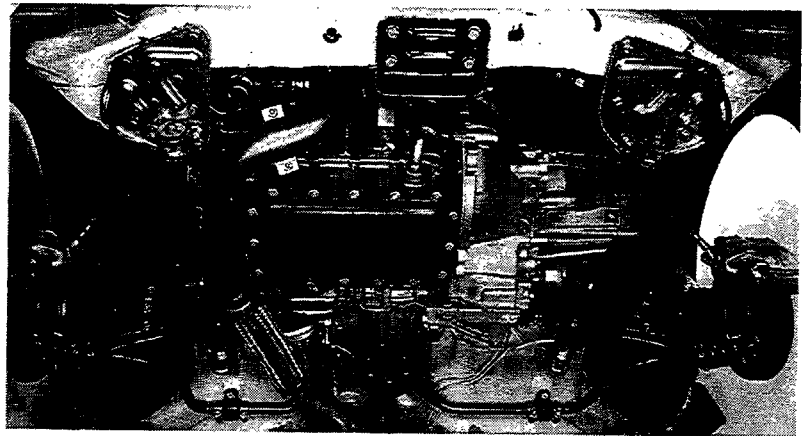

#### Removing nuts fixing constant velocity joints

Before removing the nuts fixing the constant velocity joints, remove the staking as illustrated in the photo.

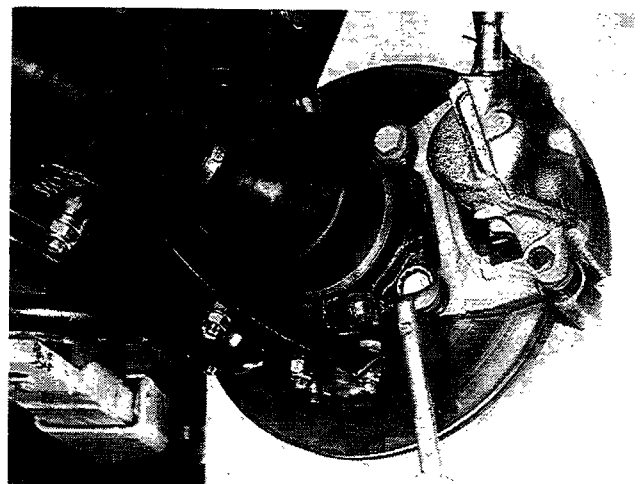
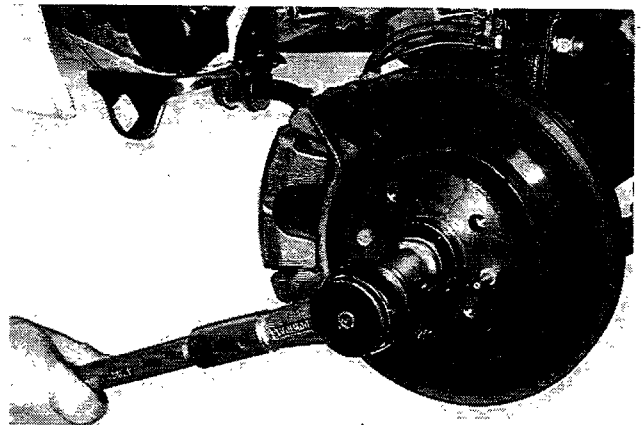
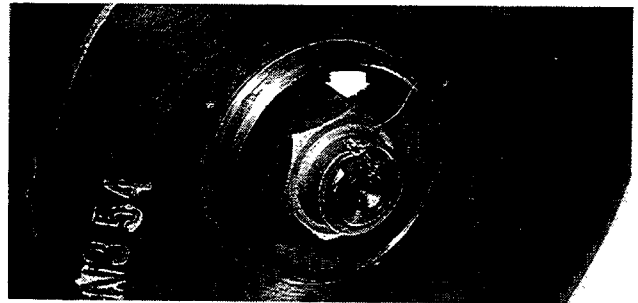

#### Removing brake caliper assembly from steering knuckle

44.

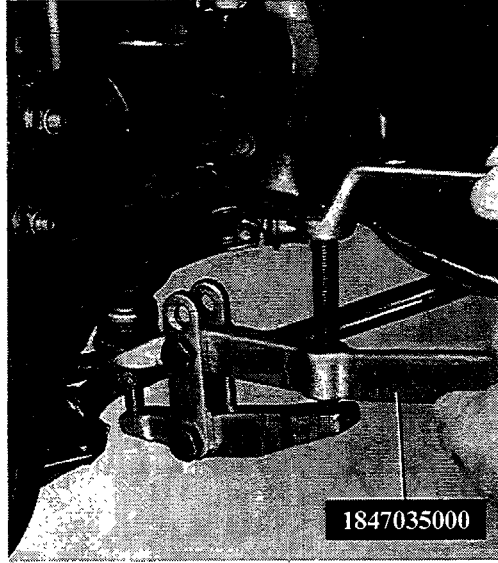
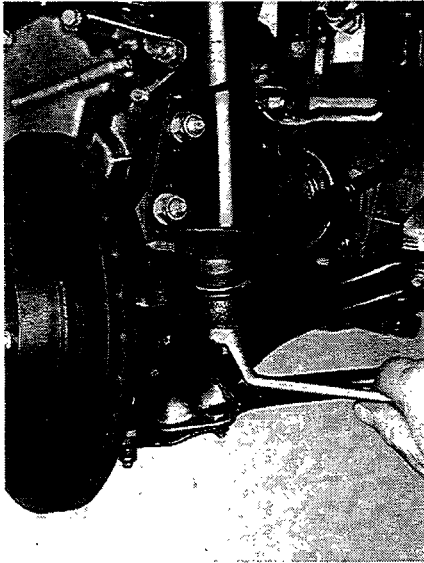

Removing ball joint pin for side steering rod

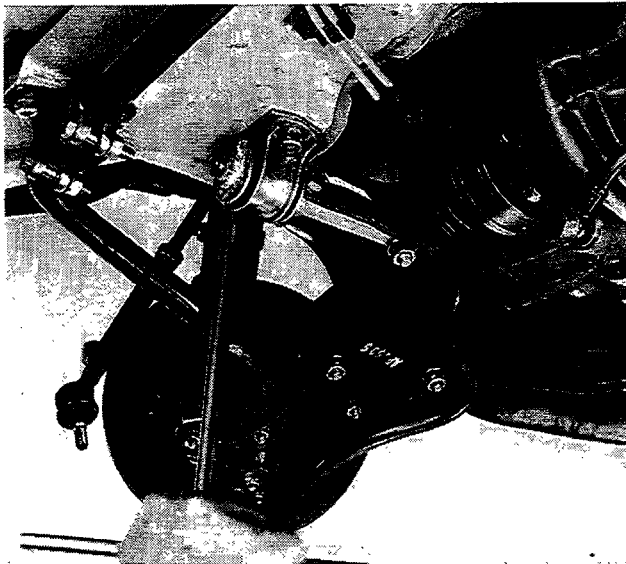

Removing track control arm from bodyshell

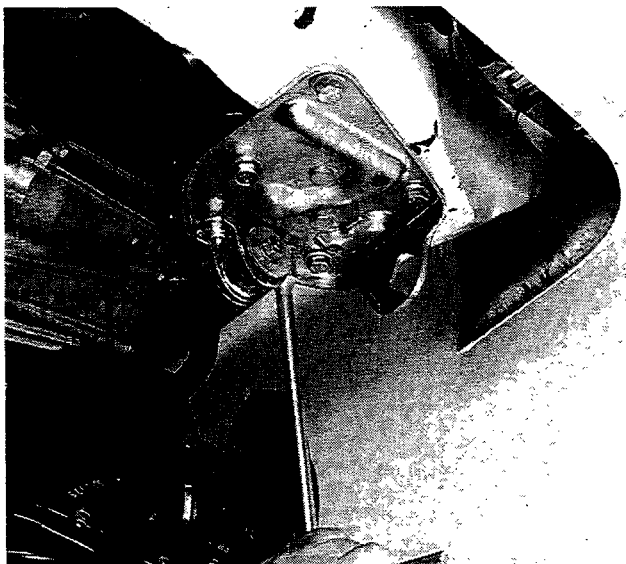

Removing strut (rod) from bodyshell

44.

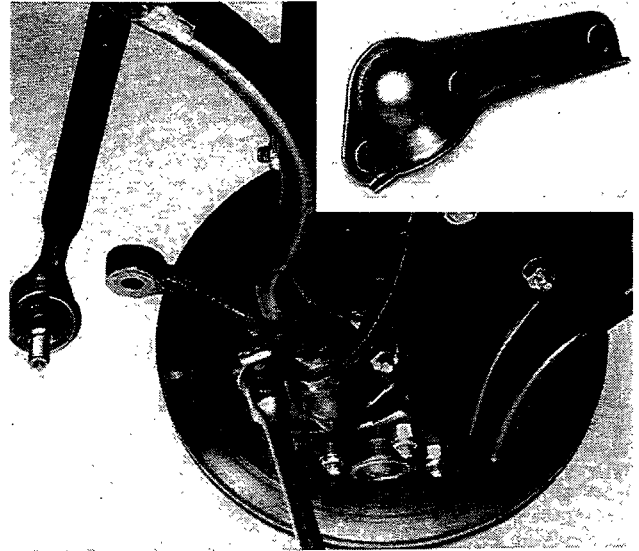

Removing stabilizer bar from track control arm

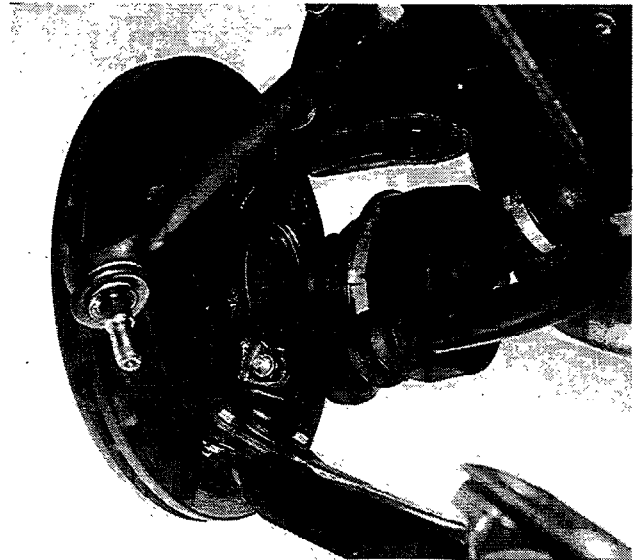

Removing drive shaft from wheel hub

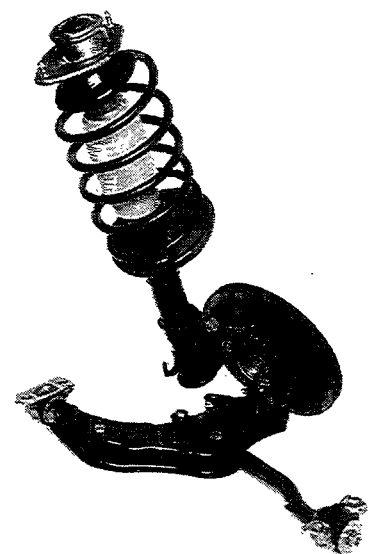
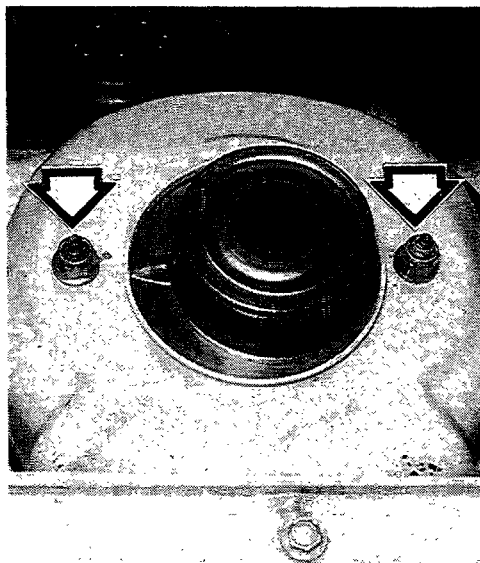

Removing shock absorber assembly from turret (engine compartment) and removing suspension unit

44.

FRONT SUSPENSION CROSS SECTION

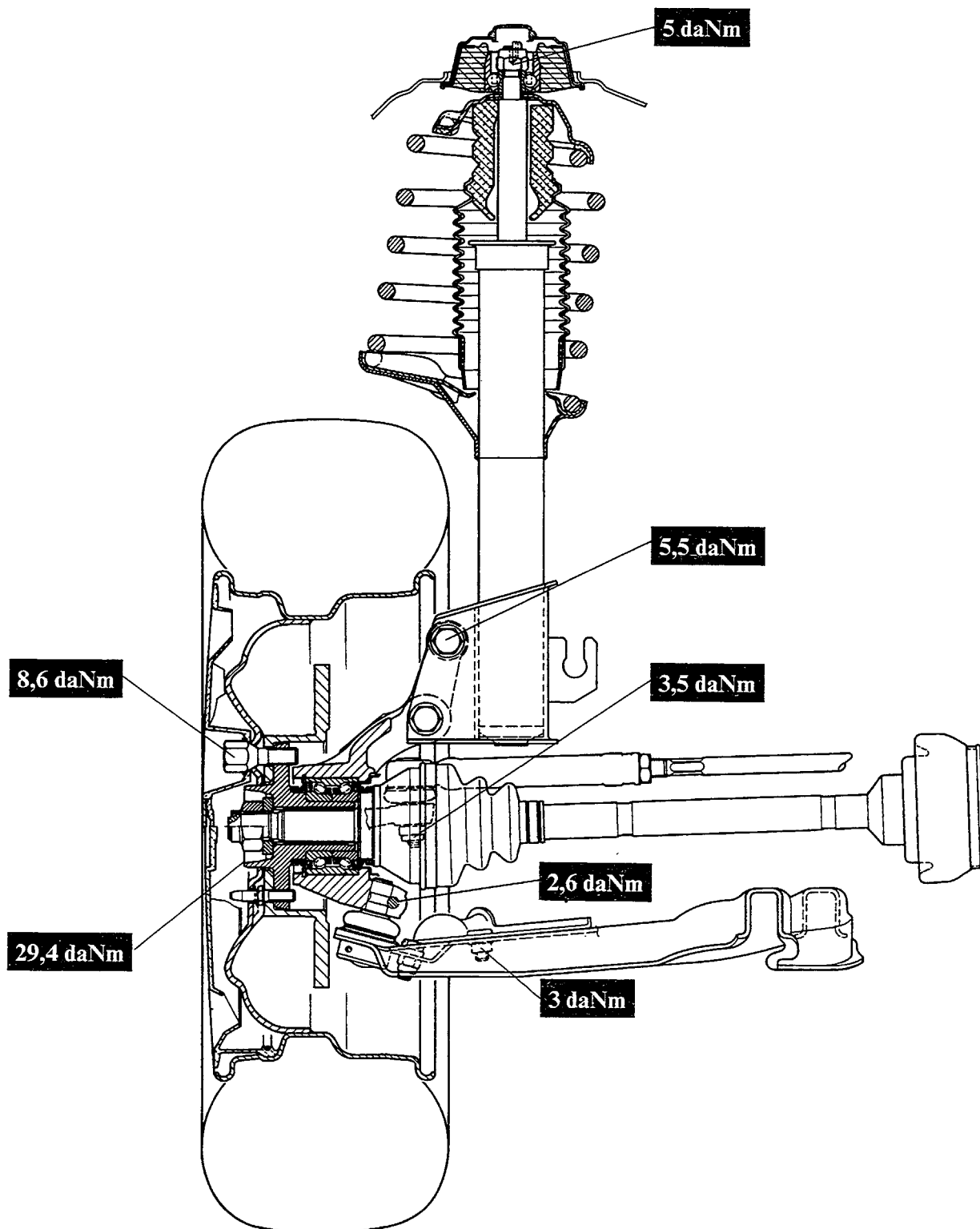

**NOTE** *In order to refit the front suspension simply reverse the order of the operations carried out for its removal.*



*The final tightening of the front suspension components should be carried out with the vehicle on a lift with 3 persons on board (2 in the front seats and 1 in the rear seats) + 20kg of luggage on the rear seat. (1 person = 70kg). The design load conditions are recreated in this way which guarantees the correct operation of the suspension components.*

29,4 daNm



### Fitting wheel hub retaining nut and tightening to torque



*The nuts fixing the constant velocity joints to the hubs should always be replaced.*

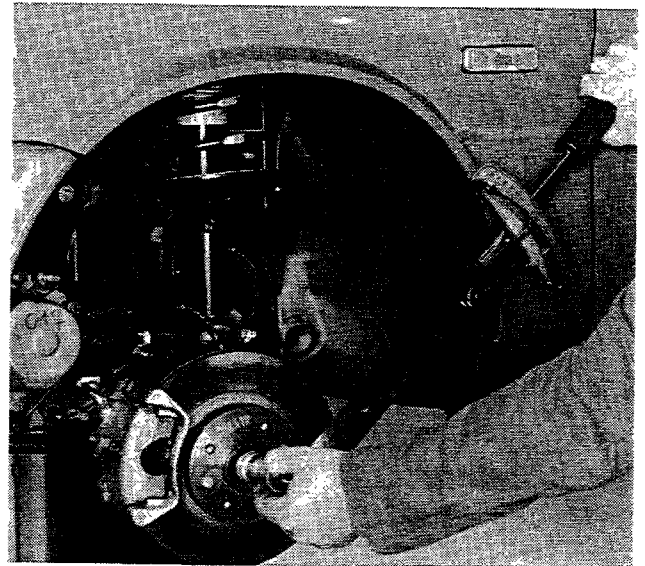

### Staking constant velocity joint fixing nut

In addition check the:

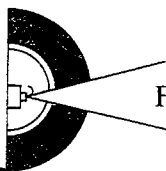

Front wheel geometry

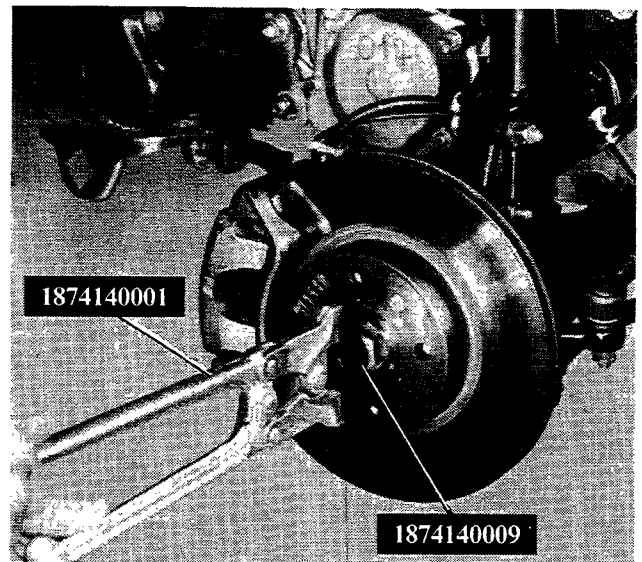

44.

Track control arm components  
available as spares

LANCIA

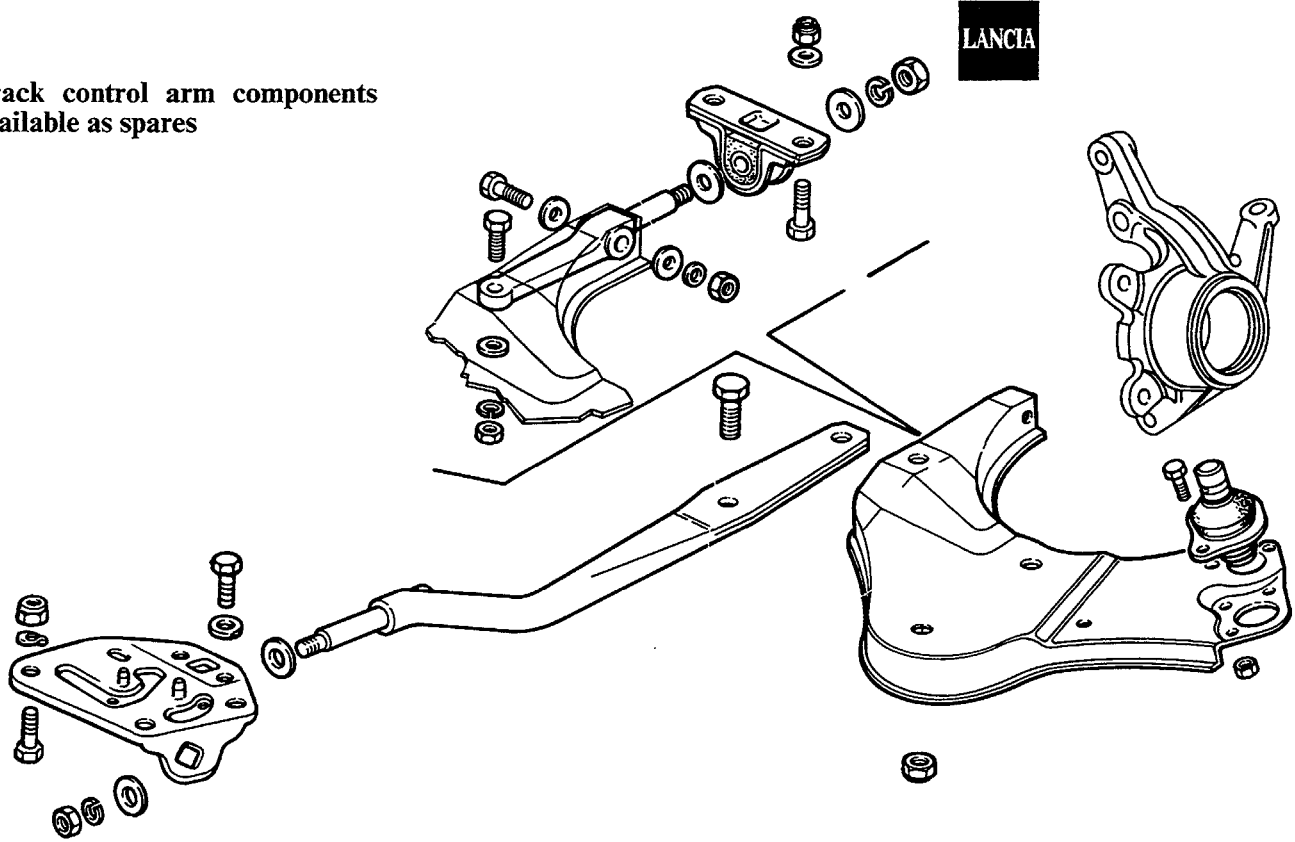

DISMANTLING-REASSEMBLY

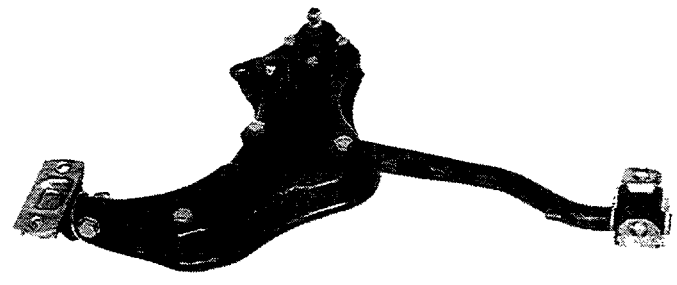
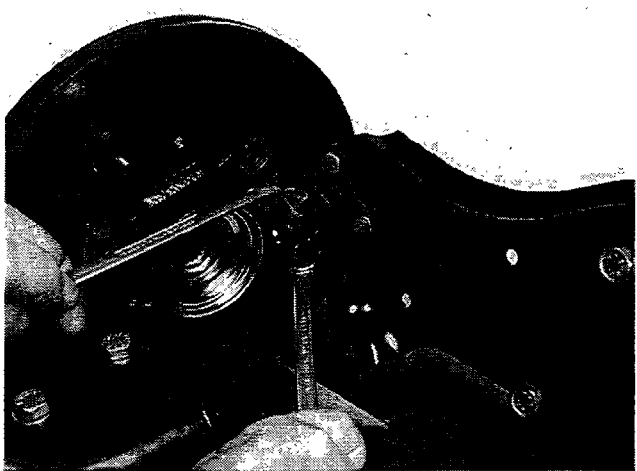

Removing-refitting track control arm from steering knuckle

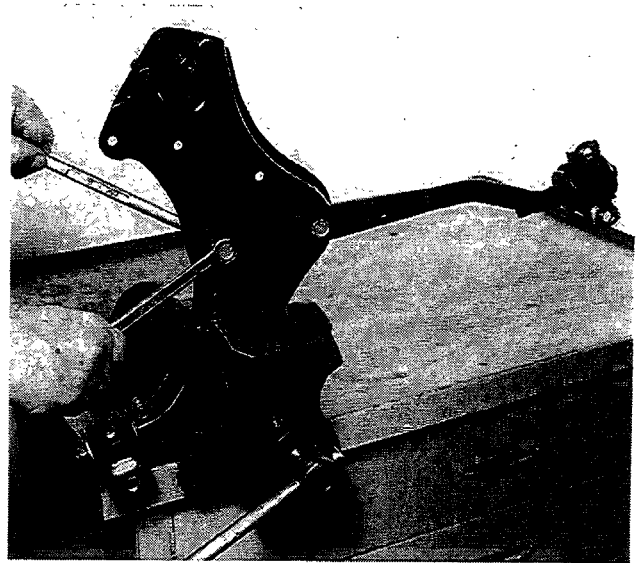

Removing-refitting strut from track control arm

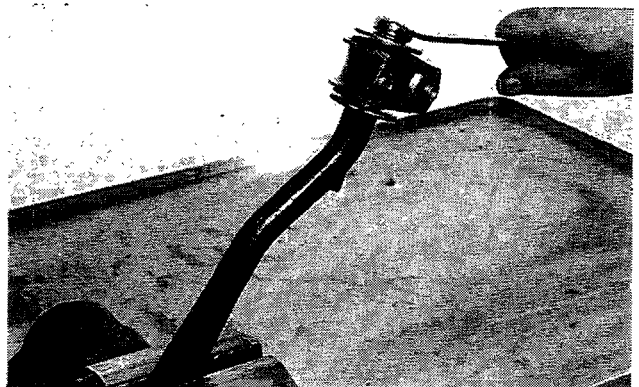

Removing-refitting flexible mounting from strut

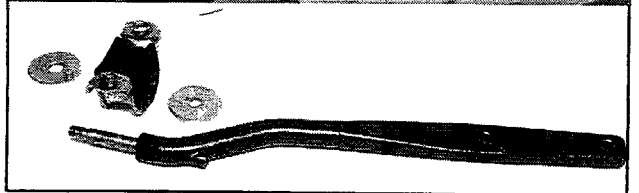

Check that the strut is not distorted and that the flexible mounting is not worn.

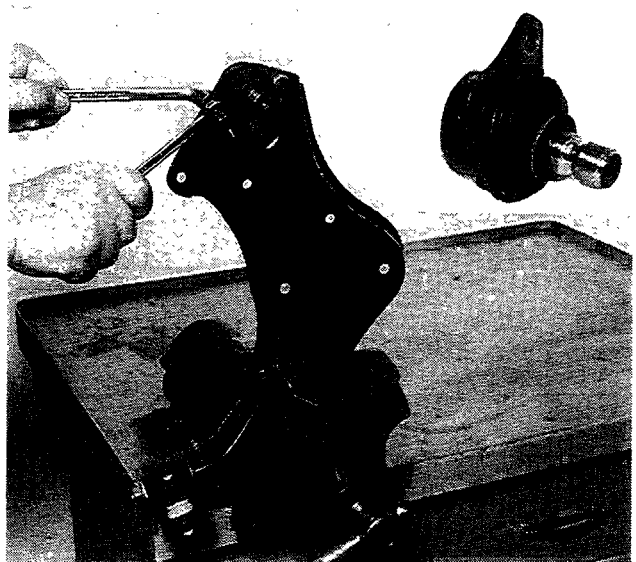

Removing-refitting ball joint from track control arm

Check that the ball joint shows no signs of grooves and that the rubber part is intact.



44.

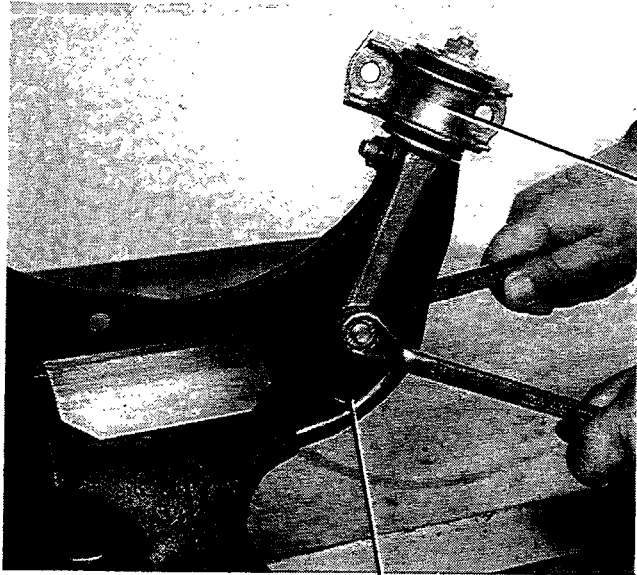

Removing-refitting flexible mounting from track control arm and dismantling at the bench

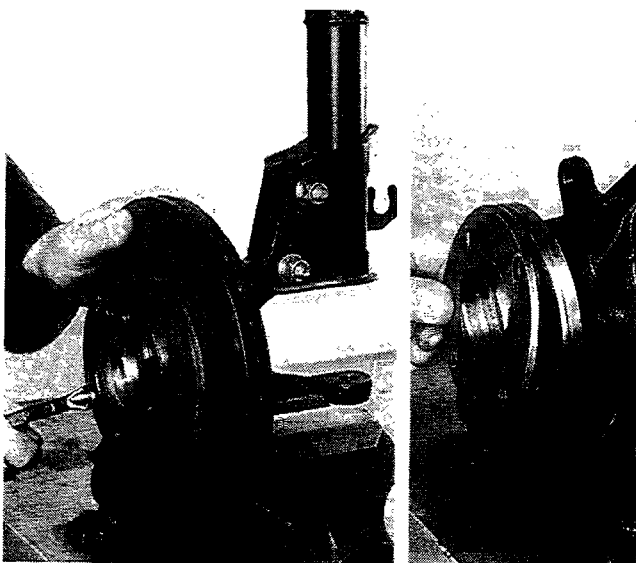
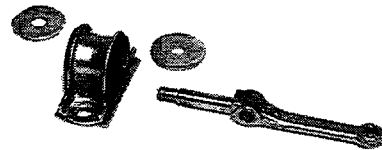
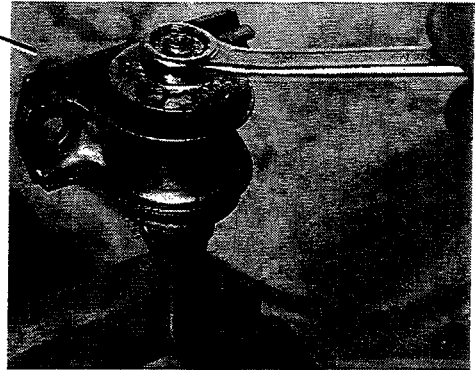

Removing-refitting brake disc and spacer

WHEEL HUB

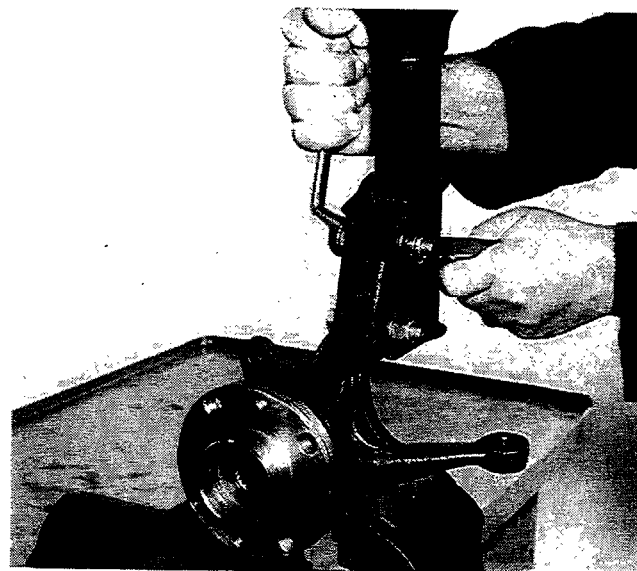

Removing-refitting shock absorber and spring from steering knuckle

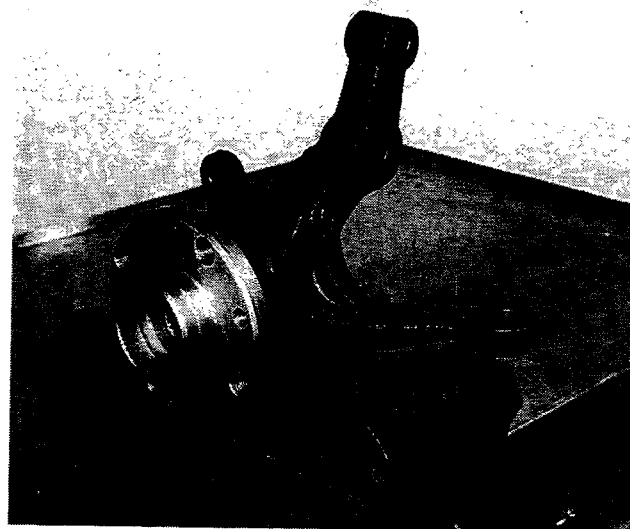

View of steering knuckle assembly

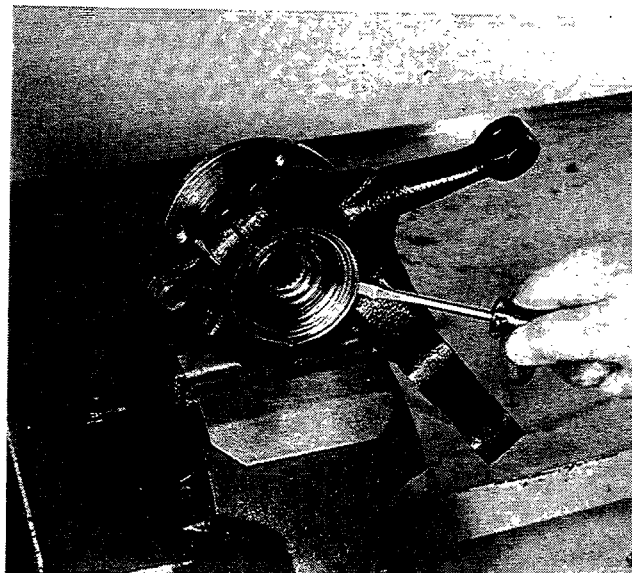

Removing dust cover cap

44.

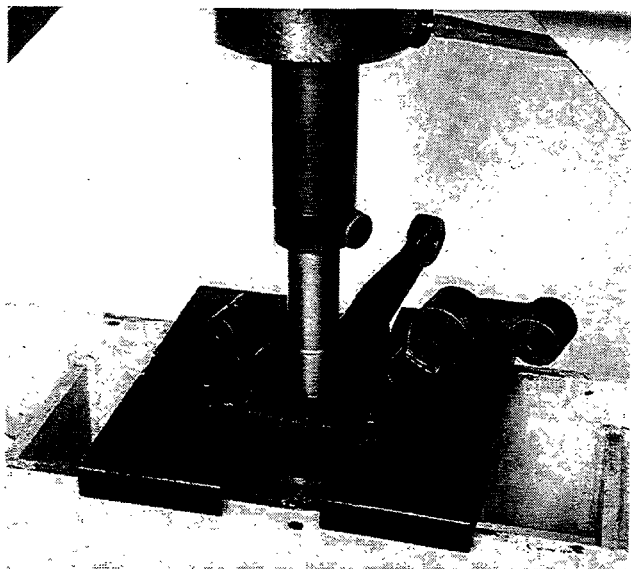

Removing hub from steering knuckle using hydraulic press



Removing-refitting dust cover cap, seal and bearing inner race from steering knuckle



Removing-refitting bearing circlip

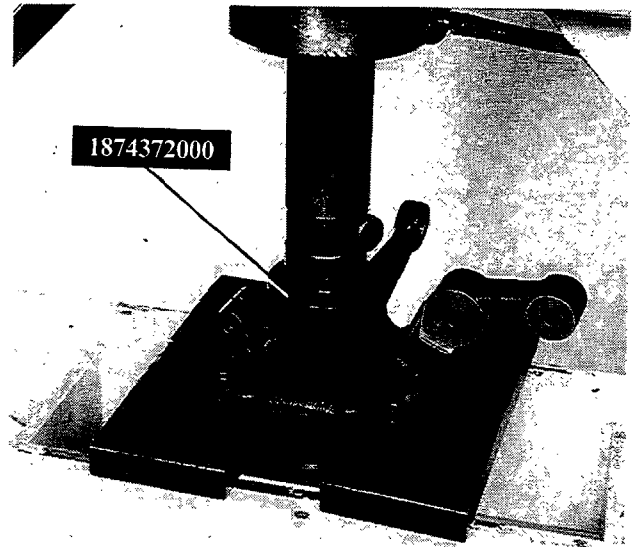

Removing outer race from steering knuckle using the hydraulic press

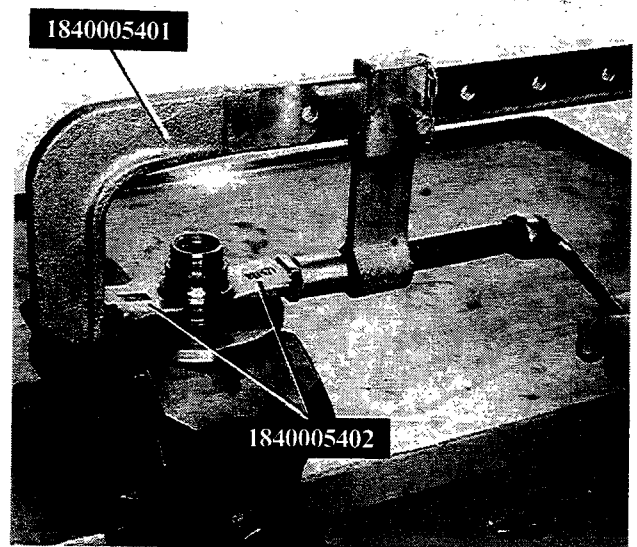

Initial removal of bearing inner race from hub

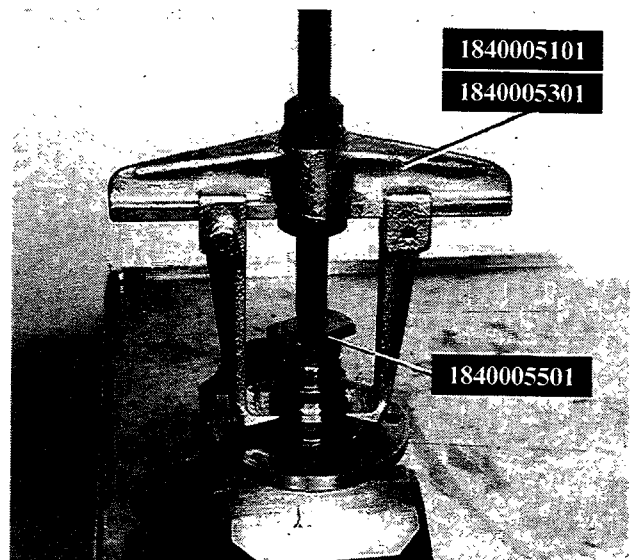

Removing bearing inner race from hub

44.

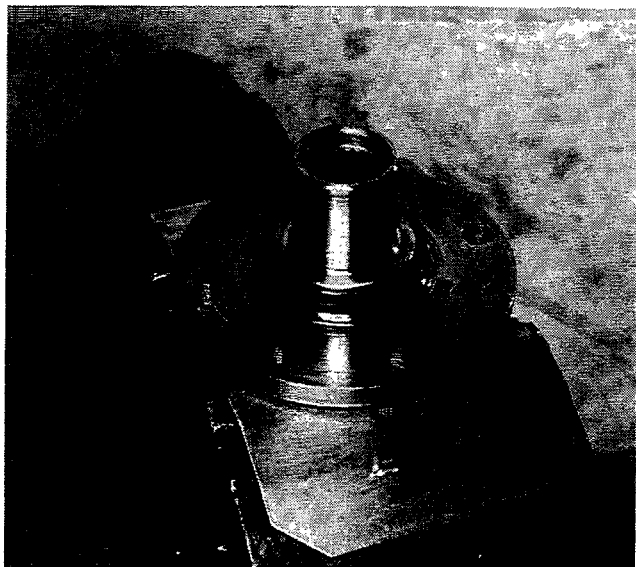

**Fitting rubber seal on hub**



*The seal generously with  
TUTELA MR 3.*

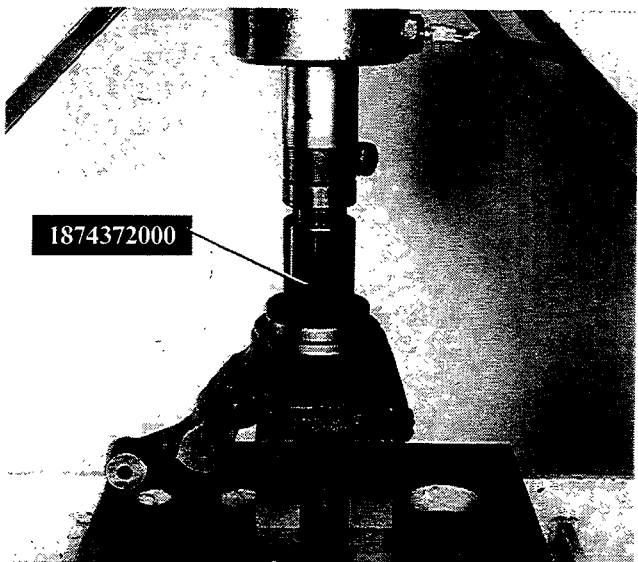

**Fitting bearing in steering knuckle on the press**

Fit the bearing circlip and the dust cover cap using tool 1874372000.

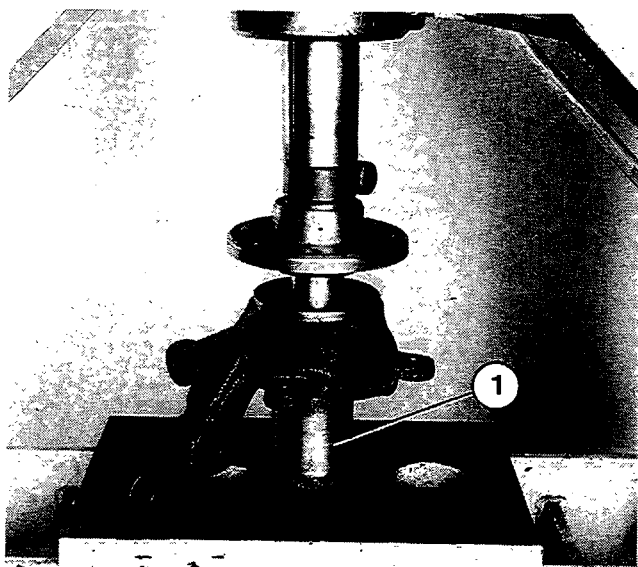

**Fitting hub in bearing on the steering knuckle**

Support the bearing inner race using a cylinder (1) of the appropriate diameter.

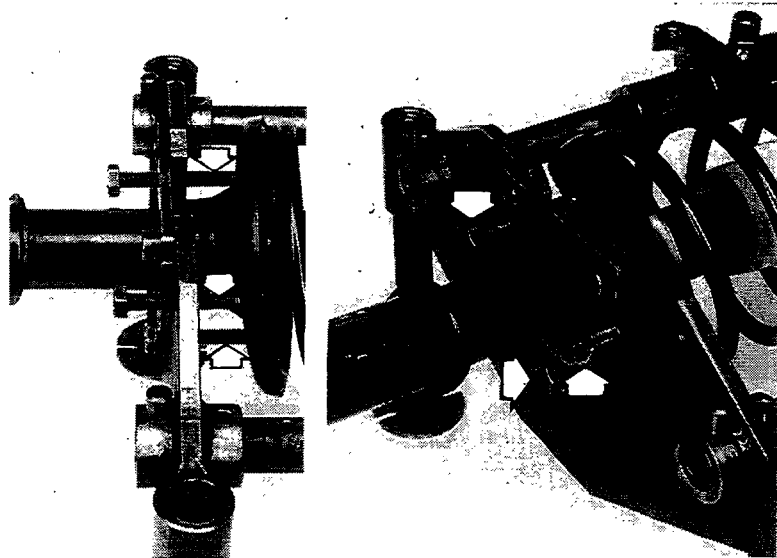

**COIL SPRING AND SHOCK ABSORBER ASSEMBLY**



**Adjusting support adjustment screws**



**NOTE** Before compressing the spring, make sure that the position of the assembly corresponds to the illustration and that the shock absorber stem is perpendicular to the support plate. This can be achieved by regulating the adjustment screws shown by the arrows.

**Shock absorber**

If any anomalies which can be attributed to the shock absorber are found, the stem is always replaced in one piece.

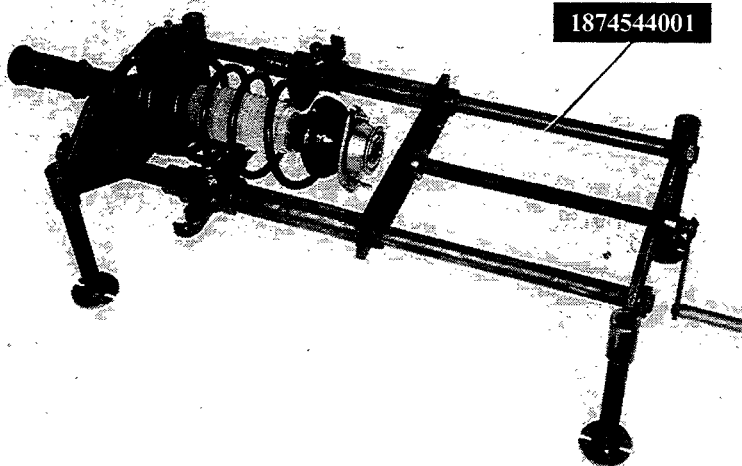

**Coil spring**

**NOTE** The coil springs are subdivided into two categories identifiable by a stripe of either yellow or green paint. Springs of the same category must be fitted.

**Removing-refitting coil spring - shock absorber assembly**



**5 daNm**

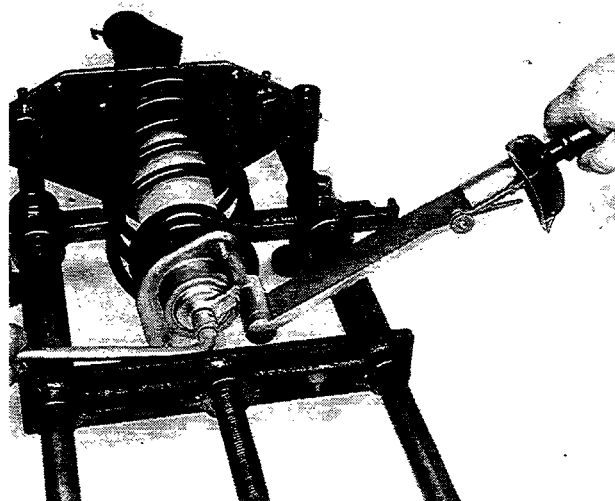

**Removing-refitting nut fixing shock absorber stem and tightening to torque**

### 44.

#### STABILIZER BAR

Removing - refitting

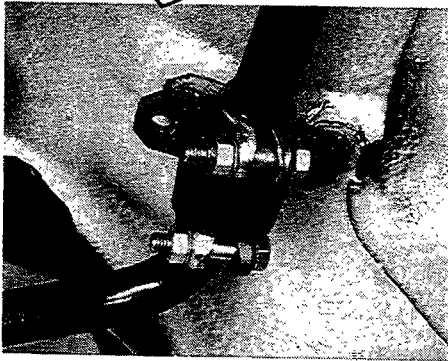
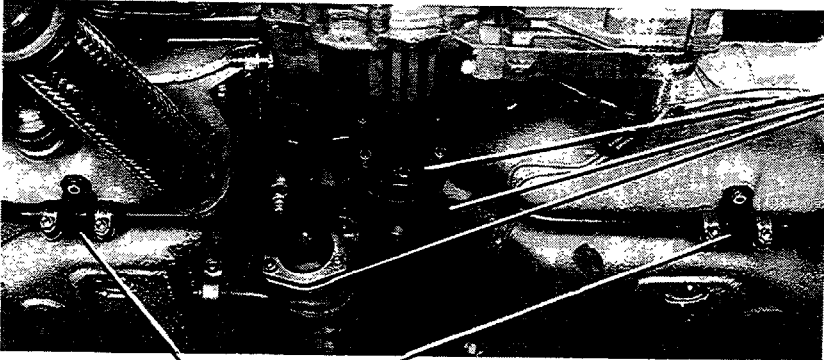

In order to remove the stabilizer bar, the drive shaft has to be removed from the front differential unit joint and the shaft support bracket and the exhaust pipe also have to be removed.

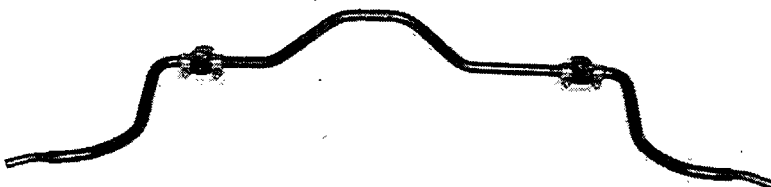
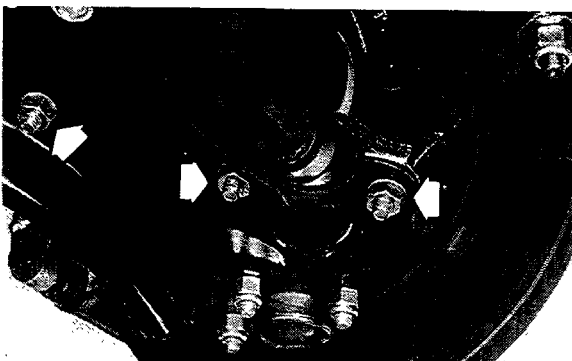

**NOTE** *To refit the stabilizer bar simply reverse the order of the operations carried out for its removal.*

REMOVING-REFITTING

View of rear suspension assembly on vehicle

In order to remove and refit the rear suspension, position the vehicle on a lift, remove the rear wheels and then proceed as illustrated below.

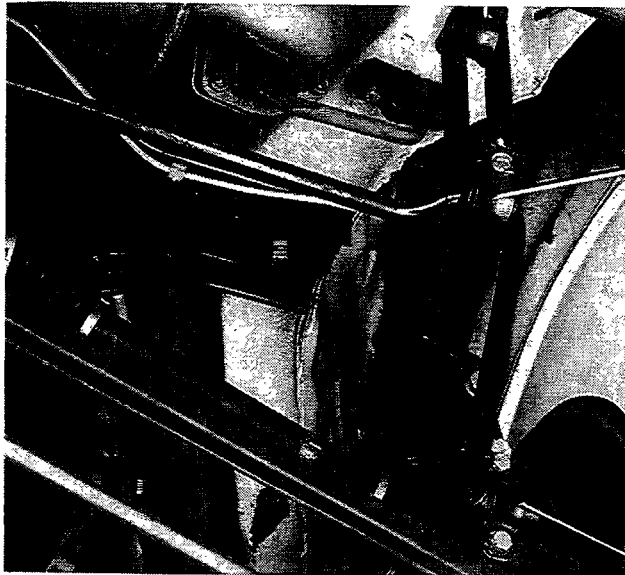
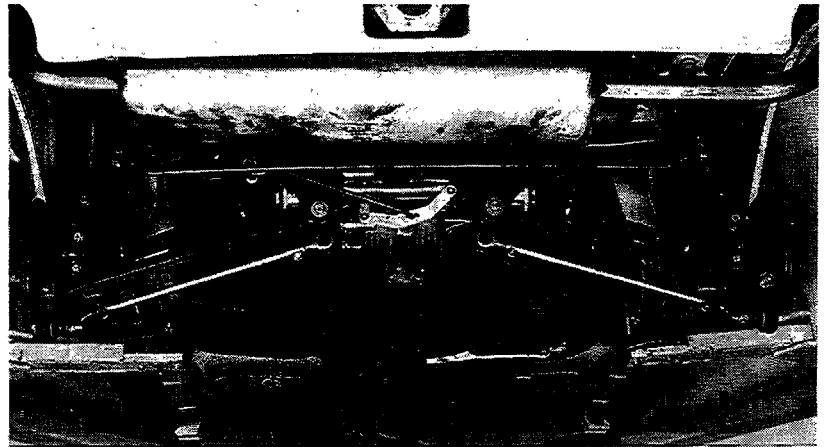

Removing stabilizer bar

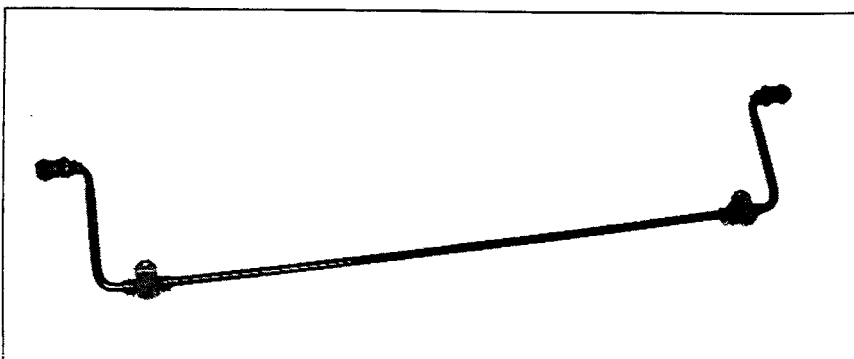
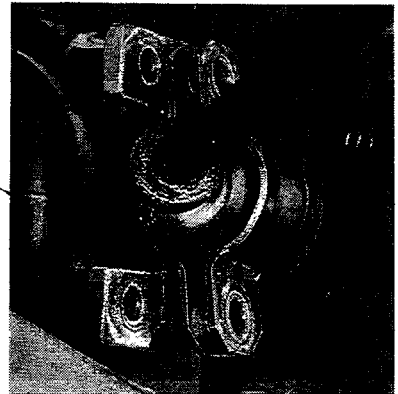
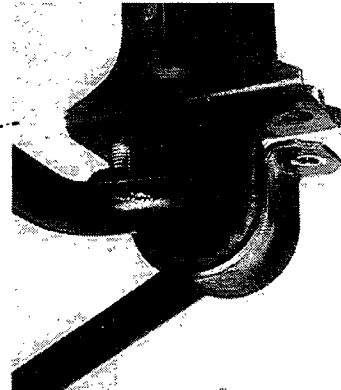

View of stabilizer bar



44.

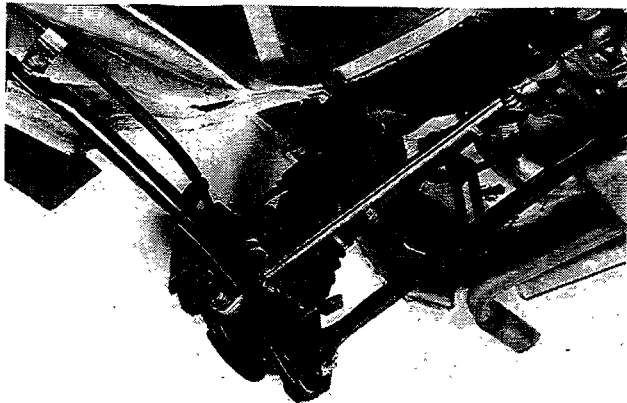

Right rear suspension unit fitted on vehicle

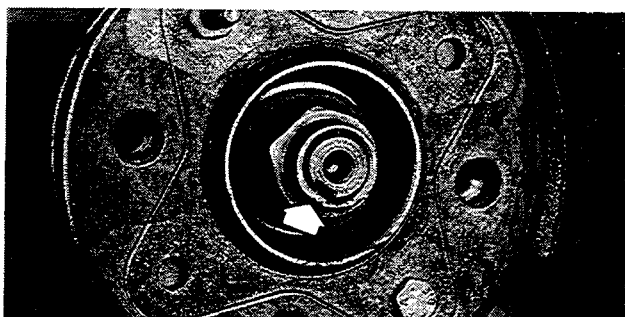

Removing nuts fixing constant velocity joints

Before removing the nuts fixing the constant velocity joints, remove the staking from them as illustrated in the photo.

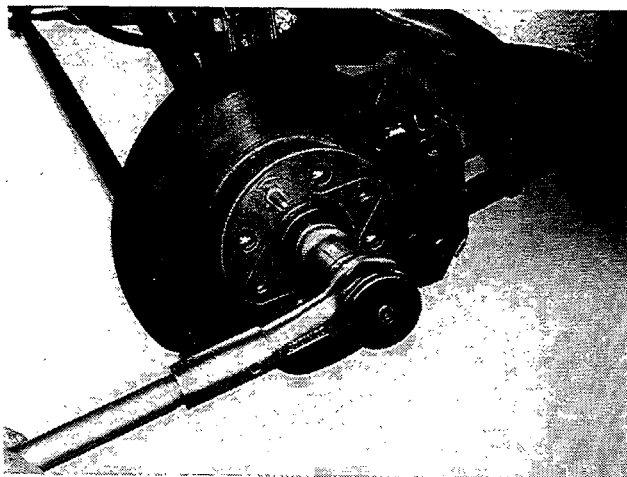

Removing longitudinal rod from the vehicle

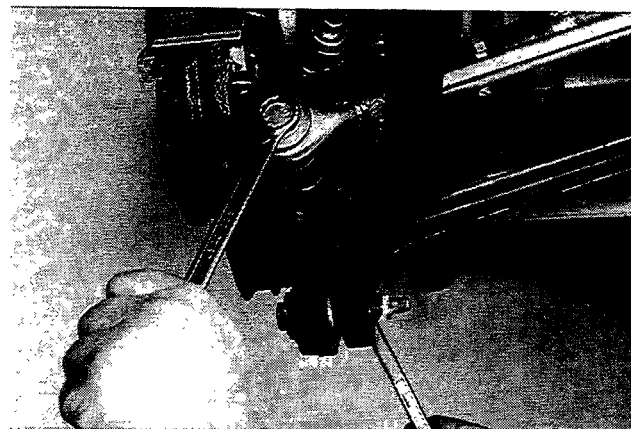

#### Removing-refitting side rod fixing nut

In order to gain access to the bolts fixing the caliper support bracket, the nut fixing the transverse rod has to be removed and moved away from the stub axle.

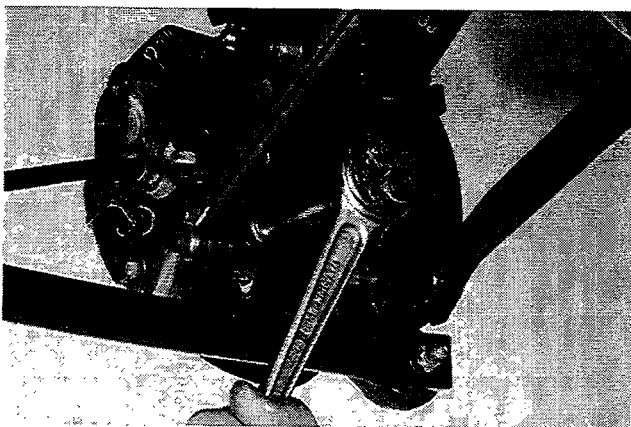
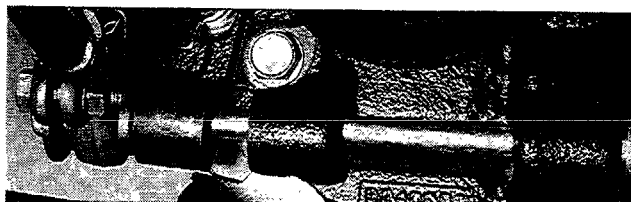

#### Removing-refitting brake caliper support bracket

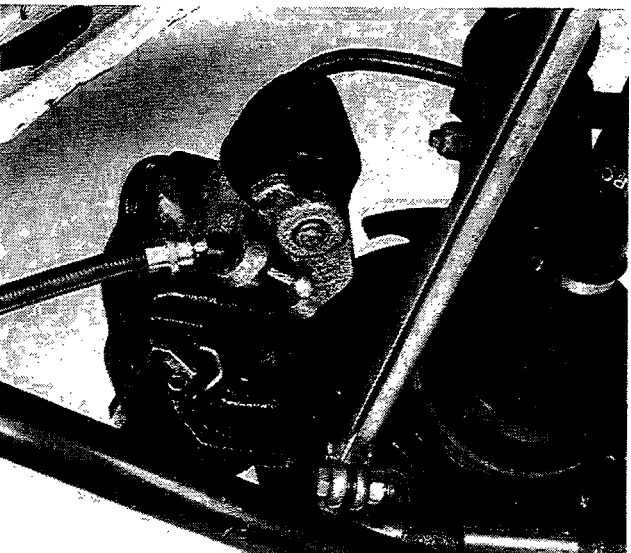

#### Removing-refitting handbrake cable from caliper device

44.

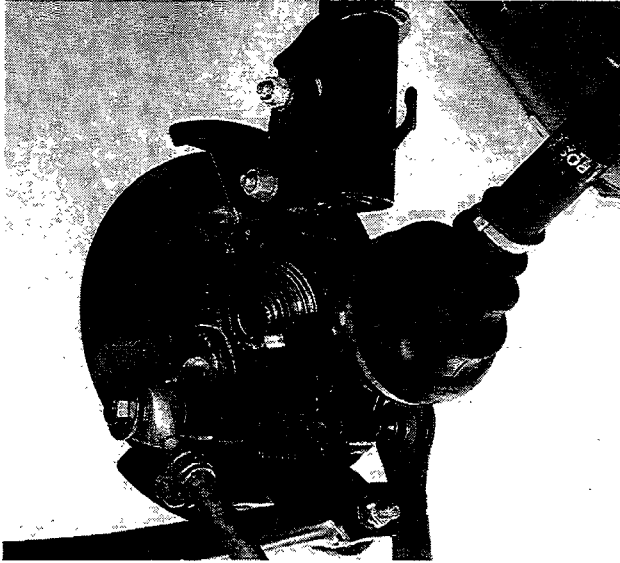

Removing drive shaft from wheel hub

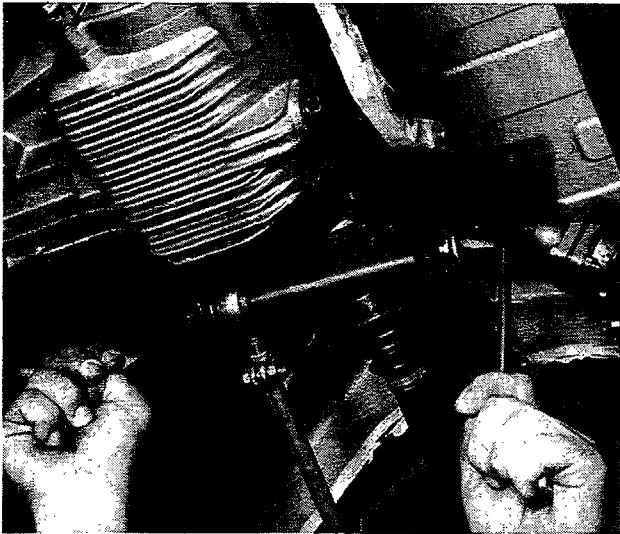

Removing-refitting transverse rods from cross member

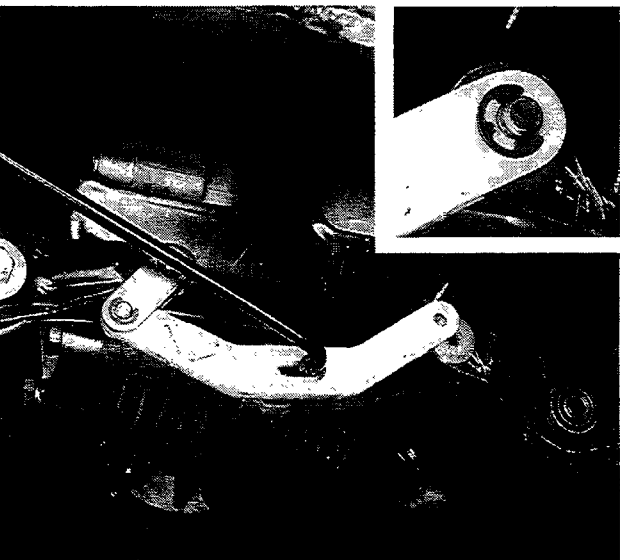

Removing-refitting load proportioning valve bar from mounting after removing clip

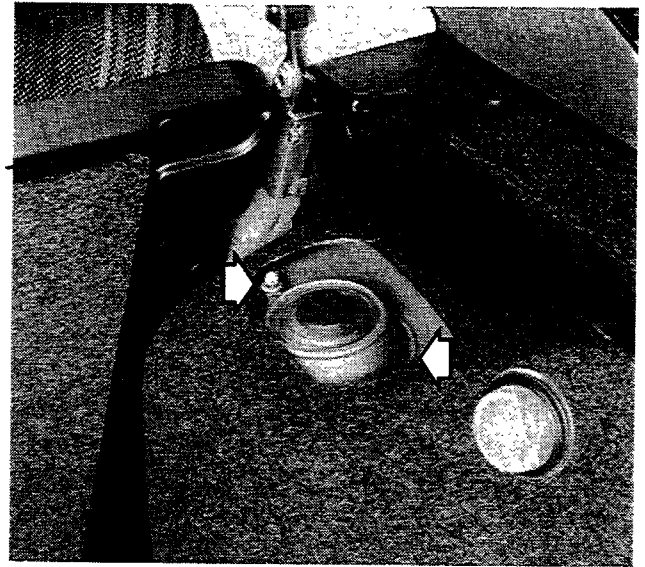

Removing-refitting shock absorber assembly from turret (luggage compartment)

### Right rear suspension unit

**NOTE** *In order to refit the right rear suspension simply reverse the order of the operations carried out for its removal.*

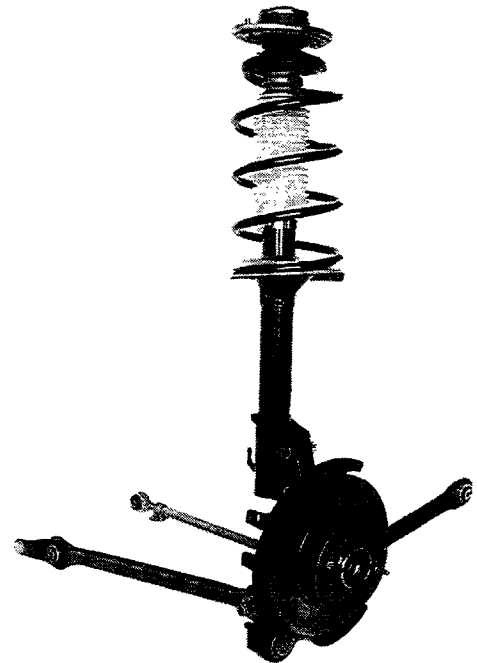

*The final tightening of the rear suspension components should be carried out with the vehicle on a lift, with 3 persons on board (2 in the front seats and 1 in the rear seats) + 20 kg of luggage on the rear seat. (1 person = 70kg). This recreates the design load conditions and guarantees the correct operation of the suspension components.*

44.



### REMOVING-REFITTING

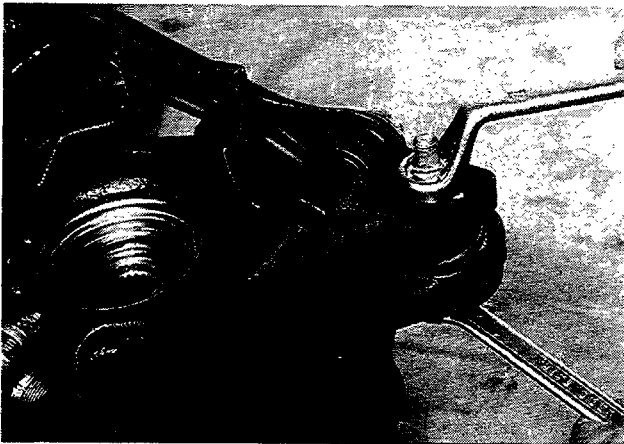

### Removing-refitting side rod

Check that the side rod is not distorted and that the flexible bush is also not distorted; if this is not the case, replace the complete rod.

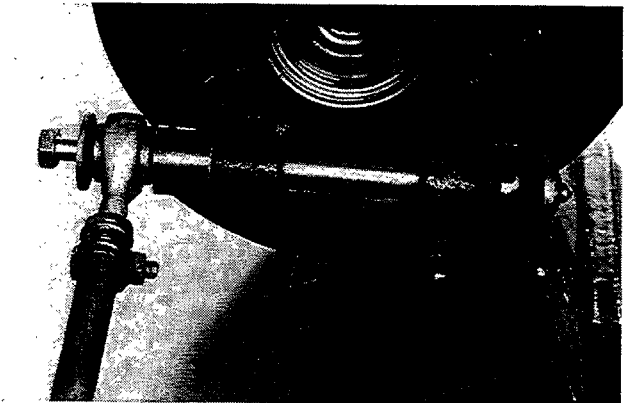
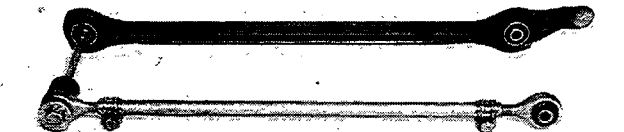

### Removing-refitting longitudinal rods

Check that the longitudinal rods are not distorted and that the flexible bushes are not worn; if this is not the case, replace the complete rods.

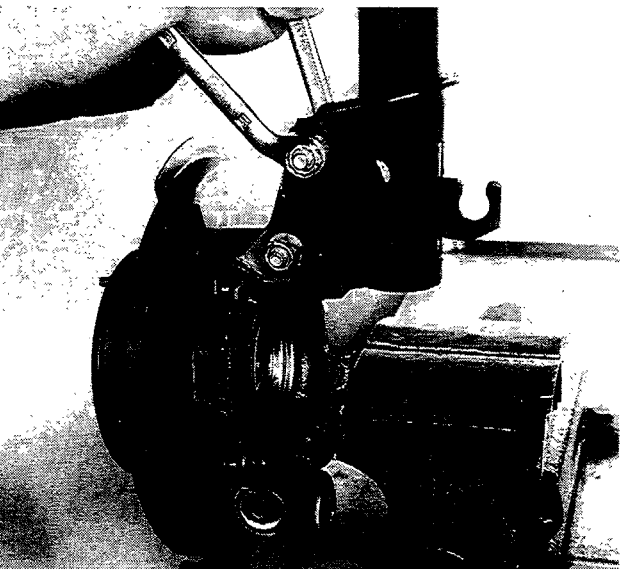

### Removing-refitting shock absorber assembly from stub axle

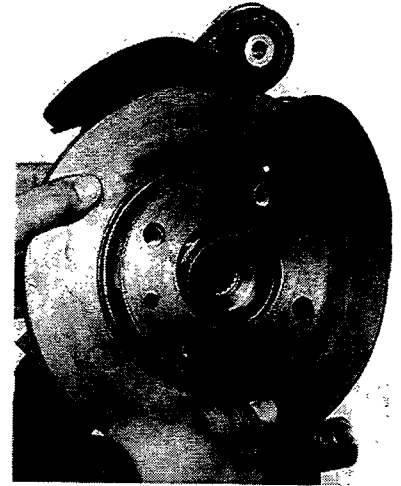
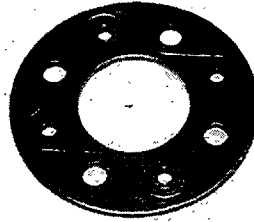
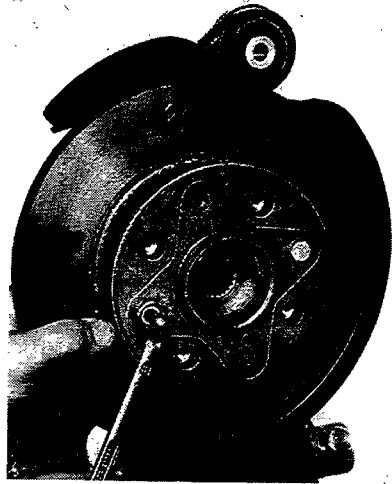

Removing-refitting spacer and brake disc

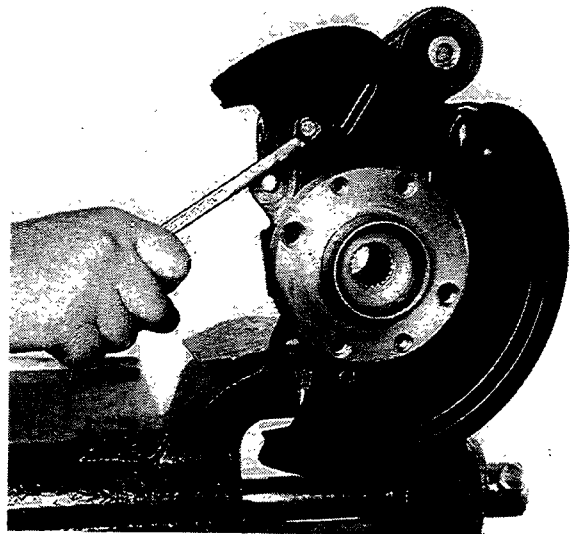

Removing-refitting dust cover disc from stub axle

WHEEL HUB

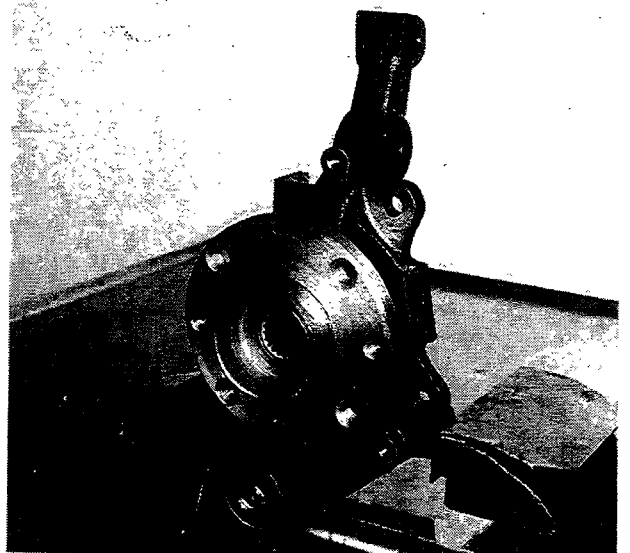

View of stub axle assembly

44.

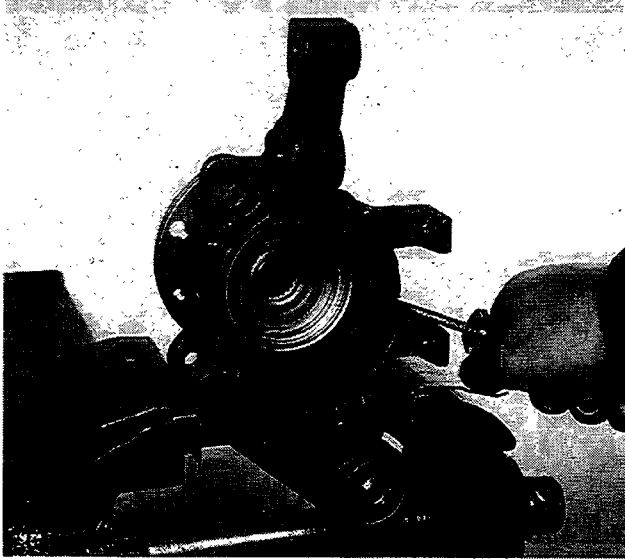

Removing dust cover cap

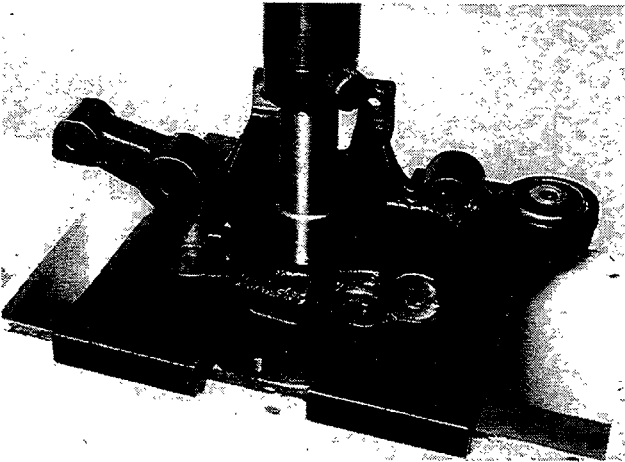

Removing hub from stub axle using the hydraulic press

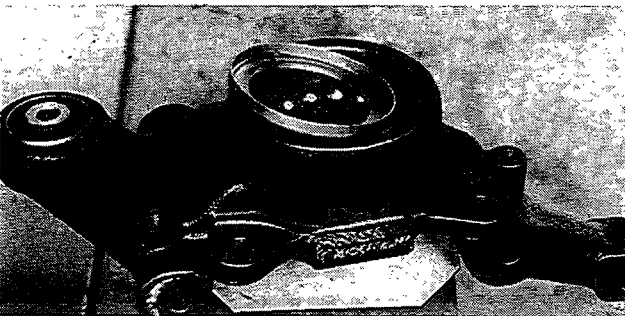

Removing-refitting dust cover cap, seal, circlip and bearing inner race from the stub axle

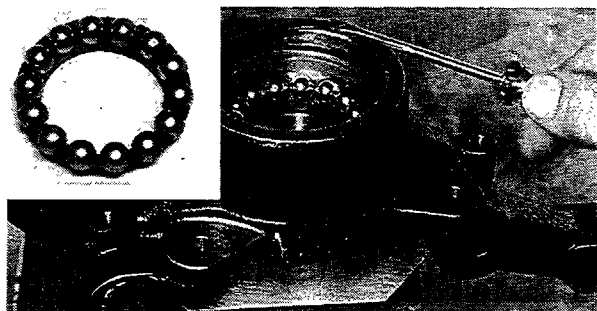
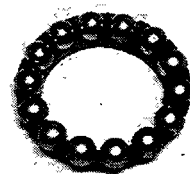

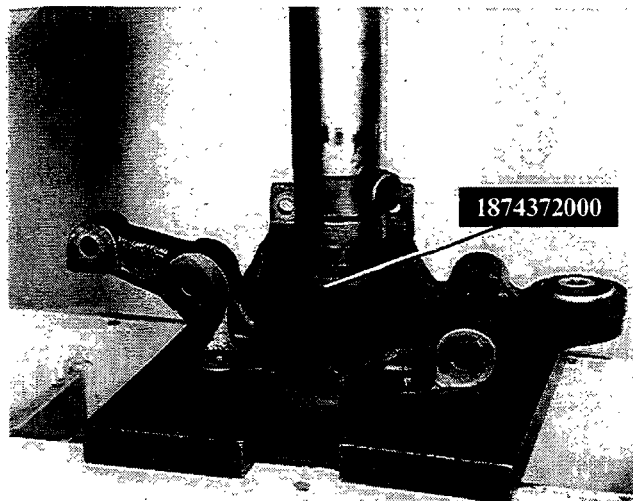

Removing bearing outer race from stub axle using hydraulic press

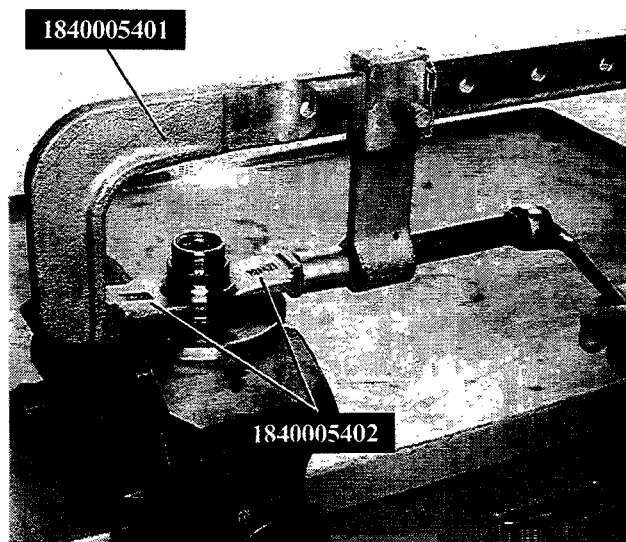

Initial removal of bearing inner race from hub

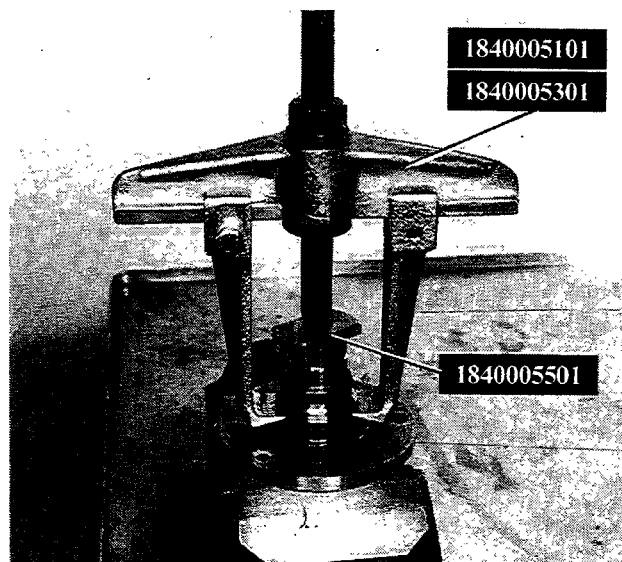

Removing bearing inner race from hub.



44.

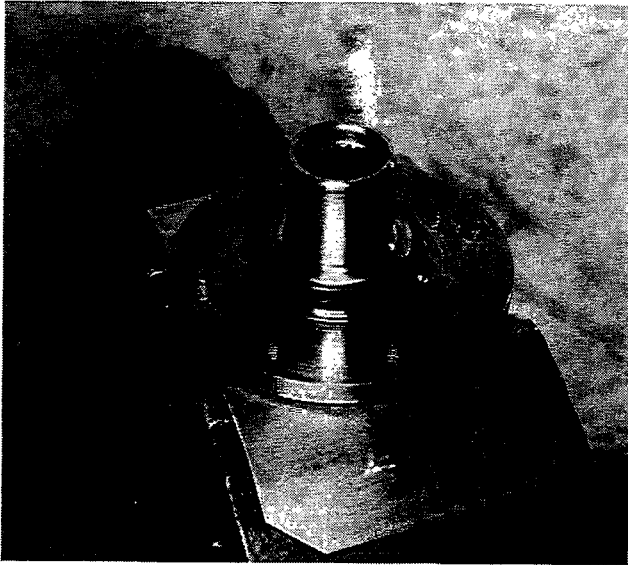

**Fitting rubber seal on hub**



*The seal generously with  
TUTELA MR3.*

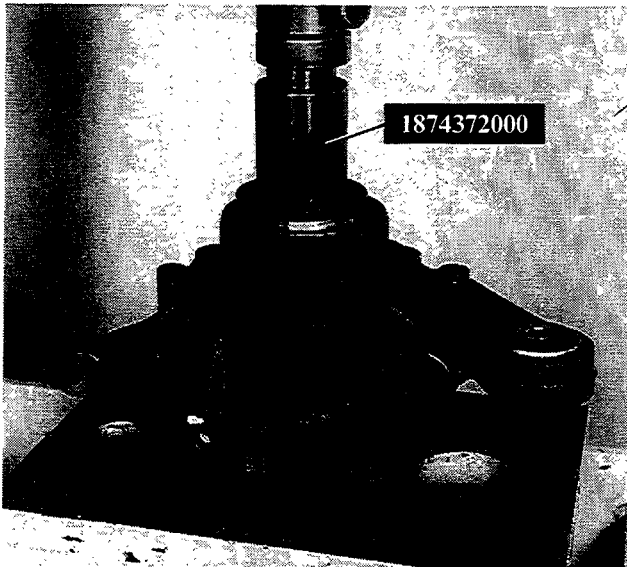

**Fitting bearing in stub axle on the press**

Fit the bearing circlip and the dust cover cap using tool 1874372000.

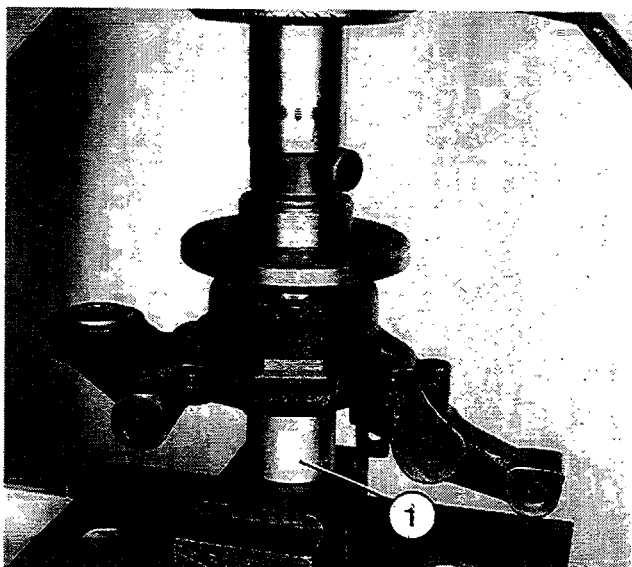

**Fitting hub in bearing on stub axle**

Support the bearing inner race using a cylinder (1) of the appropriate diameter.

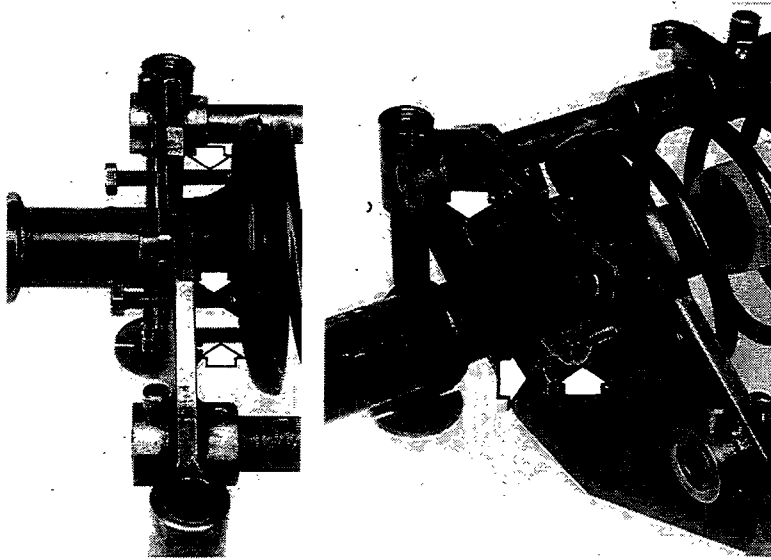

**COIL SPRING AND SHOCK ABSORBER ASSEMBLY**



Adjusting support adjustment screws



**NOTE** Before compressing the spring, make sure that the position of the assembly corresponds to that shown in the photo and that the shock absorber stem is perpendicular to the support plate. This is achieved by regulating the adjustment screws shown by the arrows.

**Shock absorber**

If any anomalies are found in the shock absorber, the stem is always replaced in one piece.

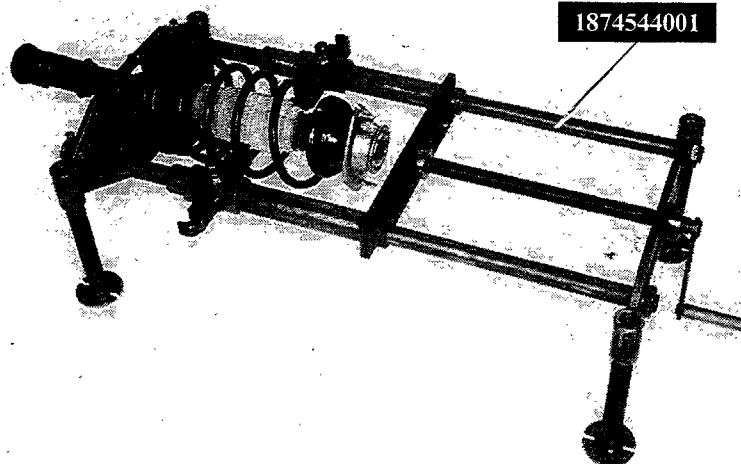

**Coil spring**

**NOTE** The coil springs are subdivided into two categories identifiable by a stripe of either yellow or green paint. Springs of the same category must be fitted.

**Removing-refitting coil spring - shock absorber assembly**



5 daNm

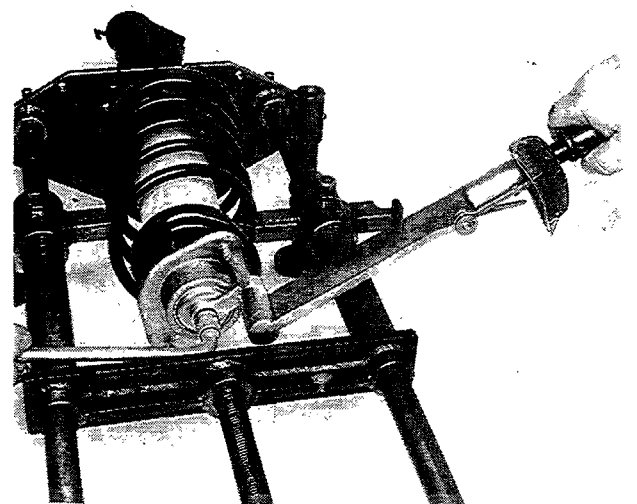

Removing-refitting nut fixing shock absorber stem and tightening to torque

## Wheel geometry

### 44.

#### FRONT WHEEL GEOMETRY

The front wheel geometry should be checked after subjecting the components affecting the wheel geometry to the following checks:

- tyre inflation pressure check;
- the eccentricity and squareness of the wheel rims should not exceed 3 mm;
- wheel bearing end float check;
- clearance between steering knuckle and track control arm ball joint;
- steering track rod end clearance.

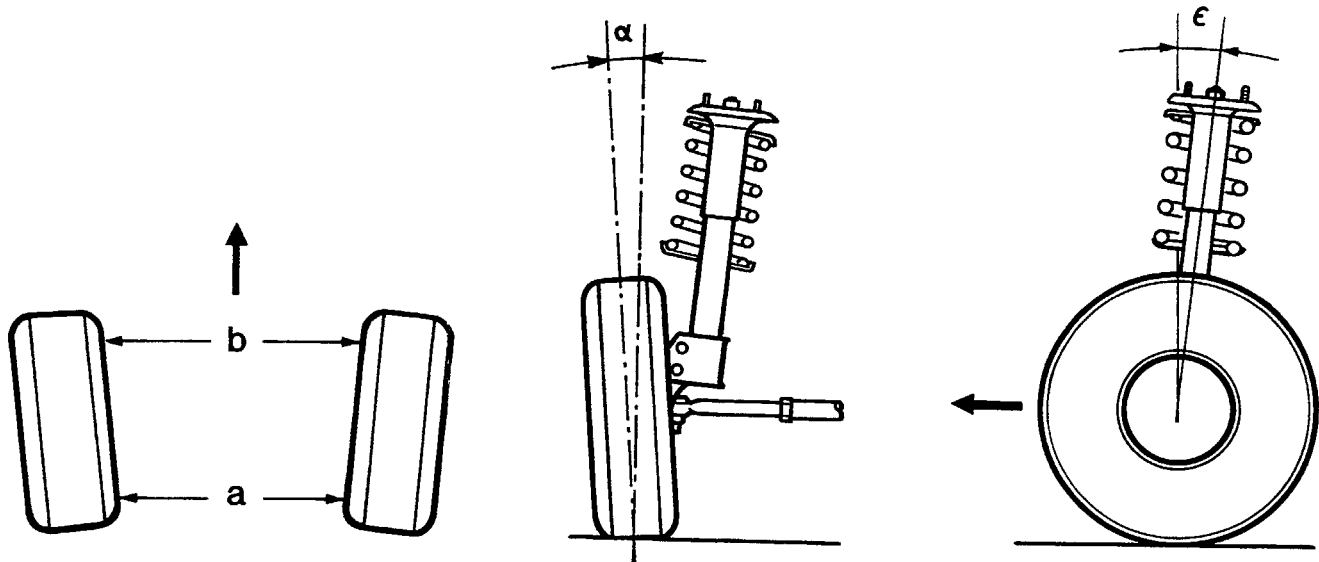

#### TOE IN

$$a - b = 2 - 1.5 \text{ mm}$$

\* Measured on the 360 mm diameter

#### CAMBER (cannot be adjusted)

$$\alpha = -40 \pm 30$$

#### CASTER (cannot be adjusted)

$$\epsilon = 3^{\circ} 10' \pm 30'$$

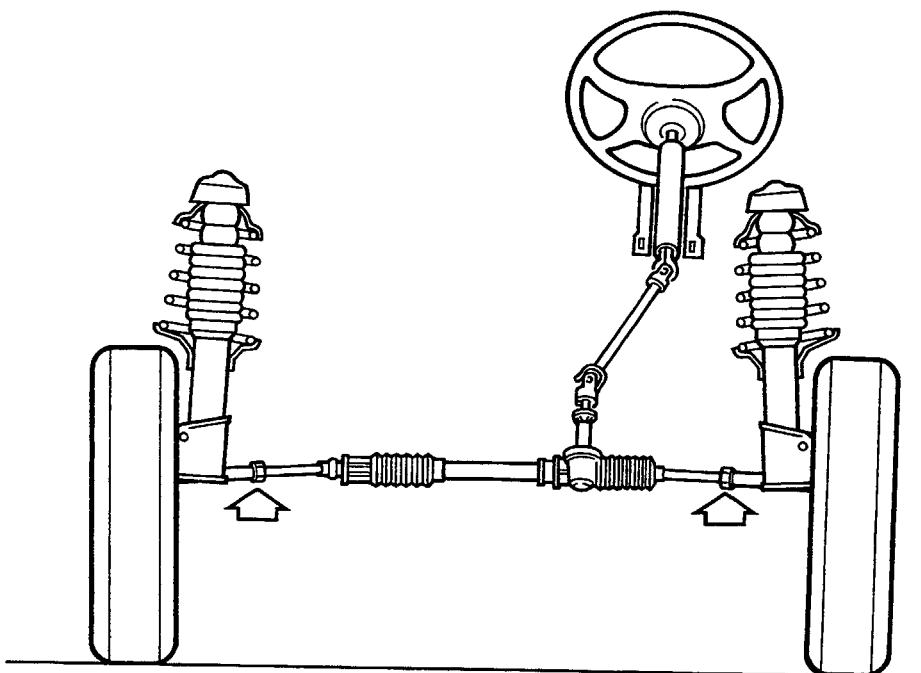

If, after checking the toe in, the values differ from the figures given, adjust the steering box rods after having loosened the fixing nuts.

**REAR WHEEL GEOMETRY**

The wheel geometry should be checked after the following checks have been carried out:

- tyre inflation pressure check;
- the eccentricity and the squareness of the wheel rims should not exceed 3 mm;
- wheel bearing end float check.

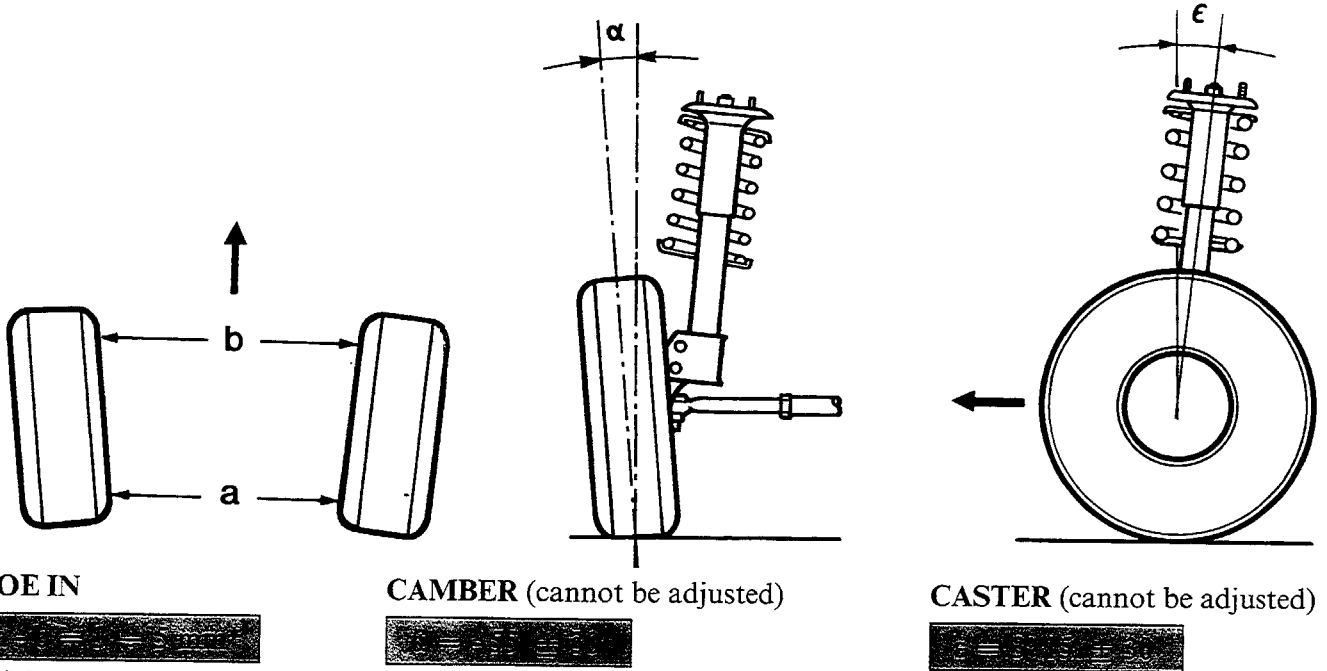

**TOE IN**

**CAMBER** (cannot be adjusted)

**CASTER** (cannot be adjusted)

\* Measured on the 360 mm diameter.

If, after checking the toe in, the values differ from the figures given, loosen the nuts (1) and turn the rod (2) until the desired conditions are achieved. The adjustment should be carried out by regulating the rods for both wheels.

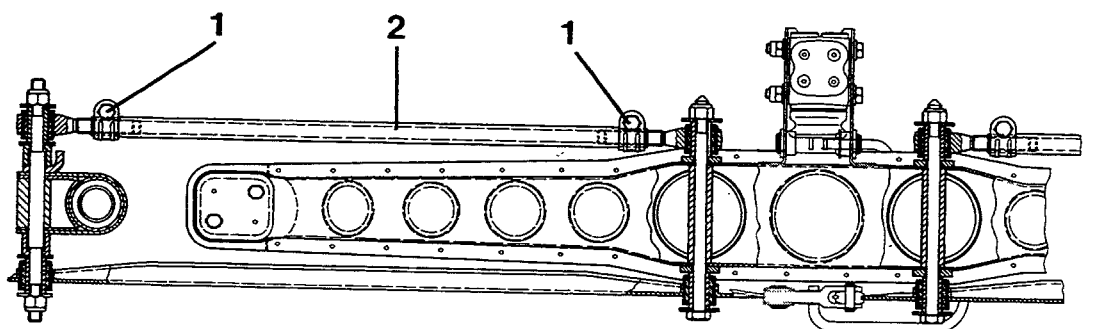
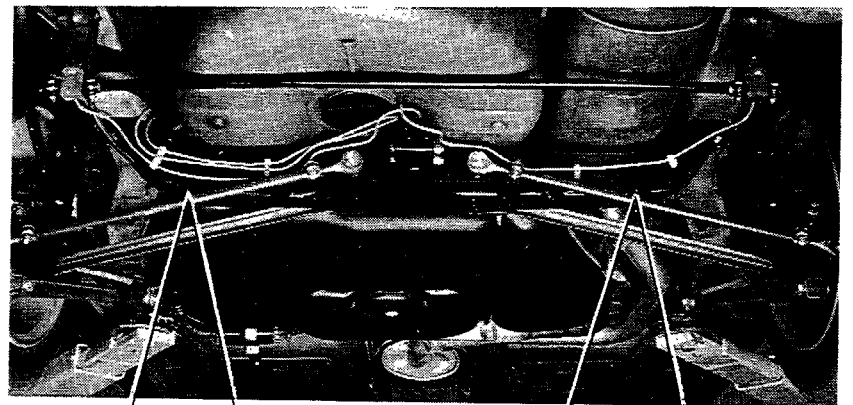

### 44.

DESCRIPTION	Thread size	Tightening torque
		daNm

#### FRONT SUSPENSION

Track rod end to ball joint fixing, bolt	M8 × 1,25	2,6
Track rod end to suspension arm fixing, bolt	M8 × 1,25	3
Ball joints to suspension arm fixing, bolt	M10 × 1,25	5,6
Ball joints to suspension arm fixing, bolt	M10 × 1,25	5,6
Flexible bushes to suspension arm fixing, nut	M10 × 1,25	4,5
Brackets (for suspension arm flexible bushes) to bodyshell fixing, bolt	M10 × 1,25	4
Left and right bracket to flexible bush bracket fixing, bolt	M10 × 1,25	4
Shock absorber to track rod end fixing, bolt	M10 × 1,25	5,5
Shock absorber stem to flexible mounting fixing, nut with polyammide ring	M12 × 1,25	5
Shock absorber stem flexible mounting to suspension turret fixing, nut	M8 × 1,25	1,8
Bracket (for stabilizer bar flexible mounting) to suspension arm fixing, nut	M8 × 1,25	1
Clamps to stabilizer bar fixing, bolt	M8 × 1,25	1,9
Flexible mounting to bodyshell fixing, bolt	M8 × 1,25	1,2
Rod to suspension track control arm fixing, bolt	M10 × 1,25	6
Wheel hub to constant velocity joints fixing, nut	M20 × 1,5	29,4
Wheel to hub fixing, bolt	M12 × 1,25	8,6

DESCRIPTION	Thread size	Tightening torque
		daNm

**REAR SUSPENSION**

Shock absorber to flexible mounting fixing, nut	M12X1,25	5
Shock absorber to stub axle fixing, bolt	M10X1,25	5,8
Flexible mounting to bodyshell turret fixing, nut	M8X1,25	1,8
Stabilizer bar joint to bodyshell fixing nut	M8X1,25	1,2
Stabilizer bar to joint mounting fixing, bolt	M6X1	1
Stabilizer bar to stub axle fixing, bolt	M8X1,25	2,3
Rear cross member to bodyshell fixing, bolt	M12X1,25	6
Longitudinal rod fixing, bolt	M10X1,25	6
Transverse rod fixing, bolt	M10X1,25	6
Wheel hub to constant velocity joint fixing, nut	M20X1,25	29,4
Wheel to rear hub fixing, bolt	M12X1,25	8,6